

# EC-E1 1A - Electronic circuit breaker



0903023

<https://www.phoenixcontact.com/pc/products/0903023>

Please be informed that the data shown in this PDF document is generated from our online catalog. Please find the complete data in the user documentation. Our general terms of use for downloads are valid.

Electronic circuit breaker, signal contact: 1 N/O contact, nominal current: 1 A



## Your advantages

- Error-free short-circuit detection even across long cable paths with the electronics characteristic curve
- Active current limitation to improve the capacity of the upstream power supply
- Increased system transparency with integrated floating remote indication contact (N/O)

## Commercial data

Item number	0903023
Packing unit	6 pc
Minimum order quantity	1 pc
Product key	CLA131
GTIN	4046356327992
Weight per piece (including packing)	68.916 g
Weight per piece (excluding packing)	68.25 g
Customs tariff number	85362010
Country of origin	DE

# EC-E1 1A - Electronic circuit breaker



0903023

<https://www.phoenixcontact.com/pc/products/0903023>

## Technical data

### Notes

General	When mounted in rows without convection cooling, the nominal device current should only be led to a maximum of 80% due to the thermal effect during continuous operation (100% operating factor). Special precautionary measures must be taken in systems or machines, to prevent components from restarting (e.g., use of a safety PLC). Parallel connection of multiple circuit breakers is not permitted.
---------	--

### Product properties

Product type	Device circuit breakers
Product family	EC-E
Type	DIN rail module, one-piece
Number of positions	1
No. of channels	1

### Insulation characteristics

Degree of pollution	2
---------------------	---

### Electrical properties

Fuse type	Automatic device
Maximum power dissipation for nominal condition	$\leq 0.8 \text{ VA}$
Switching capacity $I_{CN}$	Active current limitation
Fuse	electronic

### General

Operating voltage	24 V DC
	18 V DC ... 32 V DC
Nominal current $I_N$	1 A
Rated surge voltage	0.5 kV
Tripping method	E (electronic)
Required backup fuse	not required, integrated failsafe element
Dielectric strength	max. 32 V DC (Load circuit)
Switch off	typ. $1.8 \times I_N$
Active current limitation	active
Fuse	electronic
Closed-circuit current range $I_0$	typ. 25 mA $\pm 5$ mA (When switched on)
MTBF (IEC 61709, SN 29500)	7430000 h (at 25 °C with 80 % load)
	6590000 h (at 40 °C with 80 % load)
Voltage drop	80 mV (at $I_N$ )
Contact switching type	without electrical isolation

### Load circuit

Max. capacitive load	20000 $\mu\text{F}$
----------------------	---------------------

# EC-E1 1A - Electronic circuit breaker



0903023

<https://www.phoenixcontact.com/pc/products/0903023>

Switch-on delay	typ. 0.5 s
-----------------	------------

## Auxiliary contact

Contact connection type	floating signal contact
Minimum operating voltage $U_{\min}$ DC	10 V DC
Maximum operating voltage $U_{\max}$ DC	30 V DC
Minimum operating current $I_{\min}$	10 mA
Max. operating current $I_{\max}$	0.5 A

## Indicator/remote signaling

Connection name	Auxiliary contact
Switching function	N/O contact

## Connection data

Nominal cross section	16.00 mm <sup>2</sup>
Connection method	Screw connection

## Line+ / LOAD+ /0V

Connection method	Screw connection
Screw thread	M4
Tightening torque	... 1.2 Nm
Stripping length	10 mm
Conductor cross-section rigid	0.5 mm <sup>2</sup> ... 16 mm <sup>2</sup>
Cross section AWG	20 ... 6 (converted acc. to IEC)
Conductor cross-section flexible	0.5 mm <sup>2</sup> ... 16 mm <sup>2</sup>
Conductor cross-section, flexible [AWG]	20 ... 6 (converted acc. to IEC)
Conductor cross-section flexible (ferrule without plastic sleeve)	0.5 mm <sup>2</sup> ... 10 mm <sup>2</sup>
Flexible conductor cross-section (ferrule with plastic sleeve)	0.5 mm <sup>2</sup> ... 10 mm <sup>2</sup>
2 conductors with same cross section, rigid	0.5 mm <sup>2</sup> ... 4 mm <sup>2</sup>
2 conductors with the same cross-section AWG rigid	20 ... 12 (converted acc. to IEC)
2 conductors with same cross section, flexible	0.5 mm <sup>2</sup> ... 4 mm <sup>2</sup>
2 conductors with the same cross-section AWG flexible	20 ... 12 (converted acc. to IEC)
2 conductors with same cross section, flexible, with ferrule without plastic sleeve	0.5 mm <sup>2</sup> ... 2.5 mm <sup>2</sup>
2 conductors with the same cross section, flexible, with TWIN ferrule with plastic sleeve	0.5 mm <sup>2</sup> ... 6 mm <sup>2</sup>
Nominal cross section	16 mm <sup>2</sup>

## Auxiliary contact

Connection method	Screw connection
Screw thread	M3
Tightening torque	... 0.5 Nm
Stripping length	8 mm
Conductor cross-section flexible (ferrule without plastic sleeve)	0.25 mm <sup>2</sup> ... 2.5 mm <sup>2</sup>
Flexible conductor cross-section (ferrule with plastic sleeve)	0.25 mm <sup>2</sup> ... 2.5 mm <sup>2</sup>

## Line+/LOAD+/0V

# EC-E1 1A - Electronic circuit breaker



0903023

<https://www.phoenixcontact.com/pc/products/0903023>

Connection method	Screw connection
Screw thread	M4
Tightening torque	1.2 Nm
Stripping length	10 mm
Conductor cross-section flexible	0.5 mm <sup>2</sup> ... 16 mm <sup>2</sup>
Conductor cross-section rigid	0.5 mm <sup>2</sup> ... 16 mm <sup>2</sup>
Conductor cross-section AWG	20 ... 6
2 conductors with the same cross section, flexible, with TWIN ferrule with plastic sleeve	0.5 mm <sup>2</sup> ... 6 mm <sup>2</sup>
Conductor cross-section, flexible, with ferrule, with plastic sleeve	0.5 mm <sup>2</sup> ... 10 mm <sup>2</sup>
Conductor cross-section, flexible, with ferrule, without plastic sleeve	0.5 mm <sup>2</sup> ... 10 mm <sup>2</sup>

## Auxiliary contact

Connection method	Screw connection
Screw thread	M3
Tightening torque	0.5 Nm
Stripping length	8 mm
Conductor cross-section AWG	24 ... 14
Conductor cross-section, flexible, with ferrule, with plastic sleeve	0.25 mm <sup>2</sup> ... 2.5 mm <sup>2</sup>
Conductor cross-section, flexible, with ferrule, without plastic sleeve	0.25 mm <sup>2</sup> ... 2.5 mm <sup>2</sup>

## Dimensions

Width	12.5 mm
Height	83 mm
Height NS 35/15	90.5 mm
Height NS 35/7,5	83 mm
Depth	80 mm

## Material specifications

Color	black (RAL 9005)
Flammability rating according to UL 94	V0
Temperature index of insulation material (DIN EN 60216-1 (VDE 0304-21))	120 °C
Relative insulation material temperature index (Elec., UL 746 B)	130 °C

## Environmental and real-life conditions

### Ambient conditions

Degree of protection	IP20 (Housing)
Ambient temperature (operation)	0 °C ... 50 °C (non-condensing)
Ambient temperature (storage/transport)	-20 °C ... 70 °C
Humidity test	96 h, 95 % RH, 40 °C

## Standards and regulations

Standards/specifications	UL 508
--------------------------	--------

# EC-E1 1A - Electronic circuit breaker



0903023

<https://www.phoenixcontact.com/pc/products/0903023>

Standards/specifications	CSA 22.2
Note	No. 14
Standards/specifications	UL 2367
Standards/specifications	CSA 22.2
Note	No. 142
Standards/specifications	CSA 22.2
Note	No. 213
Standards/specifications	UL 1604

## Mounting

Mounting type	DIN rail: 35 mm
---------------	-----------------

Drawings

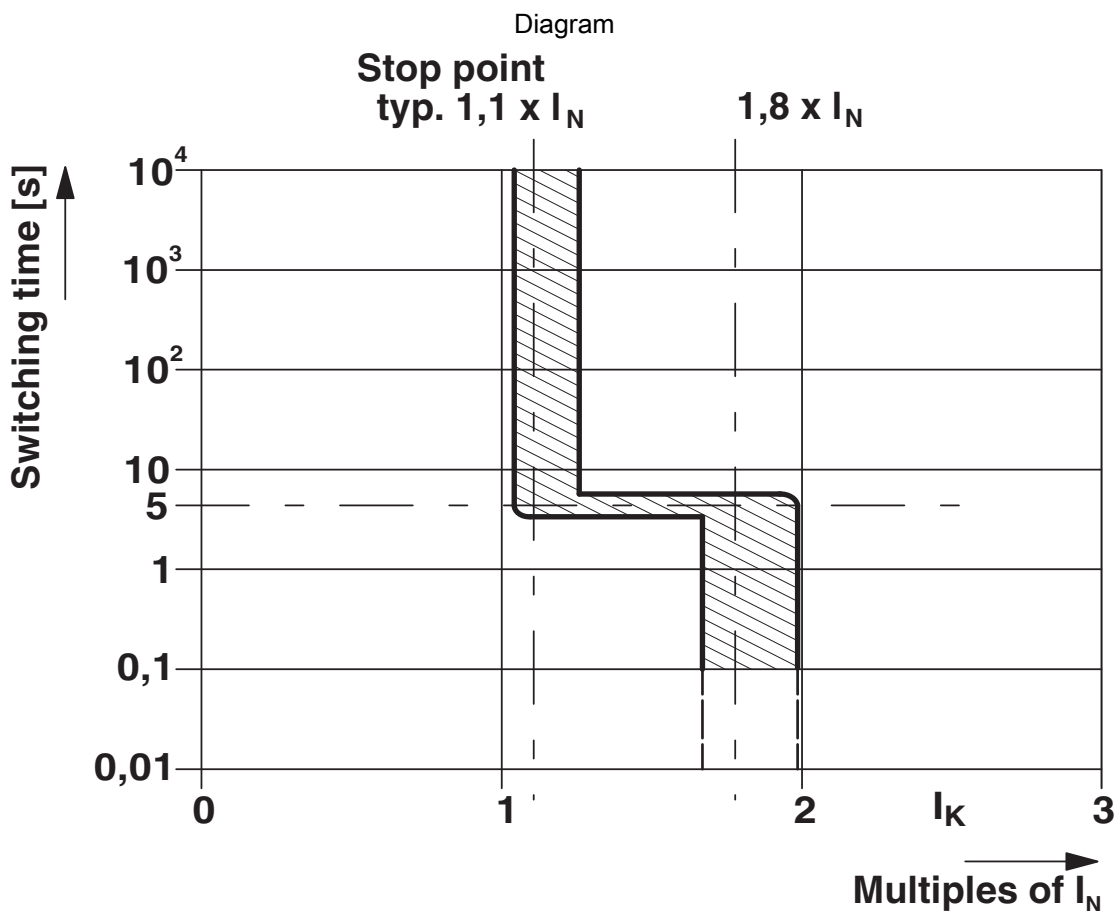

Trigger characteristic

Circuit diagram

**EC-E 1 ...**

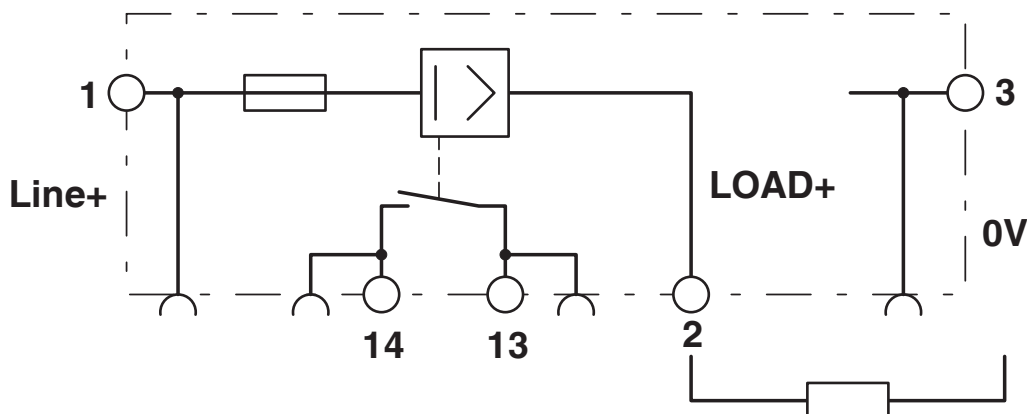

# EC-E1 1A - Electronic circuit breaker



0903023

<https://www.phoenixcontact.com/pc/products/0903023>

## Approvals

To download certificates, visit the product detail page: <https://www.phoenixcontact.com/pc/products/0903023>



**UL Recognized**

Approval ID: FILE E 317172



**DNV GL**

Approval ID: TAE00002HC



**cULus Listed**

Approval ID: E123528



**UL Recognized**

Approval ID: FILE E 324415



**CSA**

Approval ID: 2840117

# EC-E1 1A - Electronic circuit breaker



0903023

<https://www.phoenixcontact.com/pc/products/0903023>

## Classifications

### ECLASS

ECLASS-13.0	27140401
ECLASS-15.0	27140401

### ETIM

ETIM 10.0	EC003538
-----------	----------

### UNSPSC

UNSPSC 21.0	39121400
-------------	----------

# EC-E1 1A - Electronic circuit breaker



0903023

<https://www.phoenixcontact.com/pc/products/0903023>

## Environmental product compliance

### EU RoHS

Fulfills EU RoHS substance requirements	Yes
Exemption	7(a), 7(c)-I

### China RoHS

Environment friendly use period (EFUP)	EFUP-25
	An article-related China RoHS declaration table can be found in the download area for the respective article under "Manufacturer declaration". For all articles with EFUP-E, no China RoHS declaration table issued and required.

### EU REACH SVHC

REACH candidate substance (CAS No.)	Lead(CAS: 7439-92-1)
SCIP	ff3a2593-40e1-469d-ab72-cb42851bab8c

### EF3.1 Climate Change

CO2e kg	4.4 kg CO2e
---------	-------------

Phoenix Contact 2026 © - all rights reserved  
<https://www.phoenixcontact.com>

PHOENIX CONTACT GmbH & Co. KG  
Flachsmarktstraße 8  
D-32825 Blomberg  
+49 (0) 5235-3 00  
[info@phoenixcontact.com](mailto:info@phoenixcontact.com)